

[IE25H HCP]

1.5" Polish Chrome Angle Valve with hydrolator Female NPT Inlet x Female NPT Outlet.



300 lb (2070 KPa) pressure tested approved valve. Heavy Duty 1-1/2" (38 mm) chrome angle hose and hydrolator valve. Automatically drains and vents, safeguarding against hose deterioration. O-ring packing and red cast handle. Forgeline Bonnett and Seat Assembly. UL/ULC listed and FM Approved.

FINISH: Polish Chrome

Options: Cast Brass, Polish Brass, Cast Chrome



Dimensions:

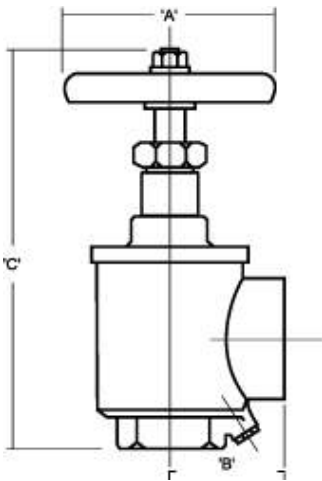

A= 4" (100mm)
B= 2 1/4" (56mm)
C= 8" (OPEN) (200mm)
C= 7" (CLOSED) ((175mm)
Weight: 4lbs 1.8Kg
Working Pressure: 300 lb (2070 Kpa)